

► SPECIFICATIONS

Alldrive 1.5 Tonne Hi-Swivel

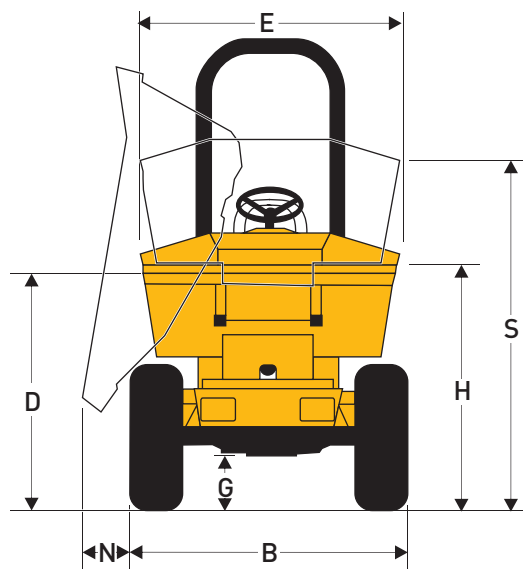
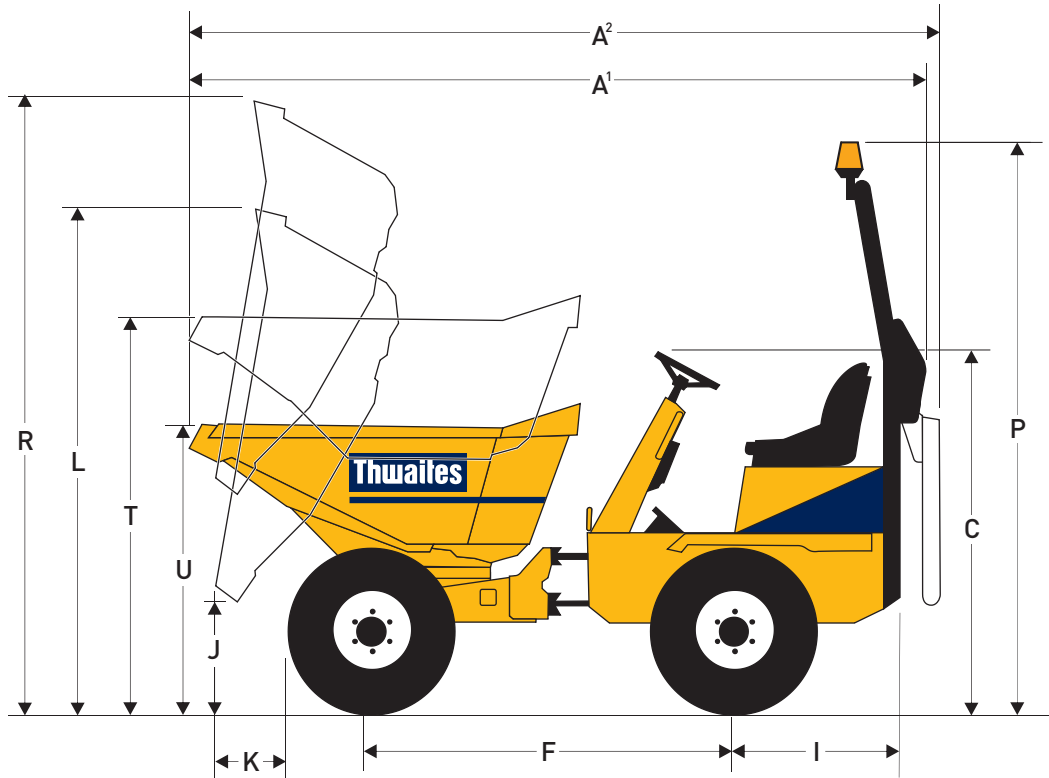

**Dimensions
(mm)**

A ¹	3715
A ²	3880
B	1467
C	1910
D	1410
E	1382
F	1850
G	275
H	1450
I	1032
J	1080
K	405
L	2790
N	231
P	3037
R	3415
S	2075
T	2035
U	1705

Load-over Height - Skip Down - 1220 mm
Skip Up - 1845 mm

► SPECIFICATIONS

Alldrive 1.5 Tonne Hi-Swivel

Capacities

Max. safe load	1500 kg
Heaped	890 litres
Struck	635 litres
Water	580 litres

Engine

Yanmar 3TNV82A, 21.1 kW/29 bhp (nett) at 2800 rpm, 3 cylinder water cooled direct injection diesel. Max torque 87 Nm (64 lbf ft). Electric starting, hour meter, battery isolator switch and heavy-duty cyclonic air cleaner positioned within the lockable engine compartment.

Noise Levels

Operator's ear 84 LpA, airborne sound power level 101 LwA (to 2000/14/EC).

Transmission

Heavy-duty gearbox, three forward, one reverse, constant mesh change on the move with nickel chrome case hardened gears. Drive through 240 mm dia spring-damped heavy-duty clutch. Transfer reduction box.

Speeds	1	4.2 km/h (2.6 mph)
	2	9.6 km/h (6.0 mph)
	3	17.8 km/h (11.1 mph)
	Reverse	4.6 km/h (2.9 mph)

Tyres	255/75 x 15.3
	8 ply
	Track grip tread

Brakes and Axles

Long-life totally enclosed multiplate oil-immersed discs mounted on front axle effective on all four wheels. Automatic adjustment for wear. Hand-operated parking brake. Heavy-duty axles with epicyclic reduction and fully floating halfshafts.

Kinglink Chassis

Front and rear chassis constructed from deep section folded steel plate, with three-point Kinglink giving centre articulation and oscillation for better stability, traction and extra safety on site. Remote greasing point provided for lubrication of top Kinglink articulation pin.

Skip

Hydraulically operated, 4 mm steel base plate, fully welded, mouth and sides of skip reinforced with box sections to minimise skip damage. Variable tipping height by means of a scissor lift. Two lever control: one with dual axis to tip and turn the skip, and a single-axis lever to adjust its height.

Seating & Controls

Adjustable suspension seat, accessible from both sides. Audible warning device at key start 'on' position. Super-bright warning lights for all critical functions. Electric horn. Large pedal pads with handbrake and hydraulic controls ready to hand.

Service Access

Lockable three-sided cover opens to provide easy access from ground level to engine service points, all located on the same side. Moulded diesel and hydraulic tanks positioned low in the chassis side members, permitting access to the filler caps from ground level.

Electrics

Wiring harness contained within conduits and all electrical components water resistant to IP65/67 standards.

Steering & Hydraulics

Hydraulic priority power steering. Filter mounted on the top of the tank accessible from ground level. Combined suction and return filtration for all services. Hydraulic test points fitted as standard.

Tank capacities	Fuel	24.5 litres
	Hydraulic	25 litres

Shipping Cube	10.9 m ³ (with folded ROPS)
---------------	--

Unladen Weight	2120 kg
----------------	---------

Clearance Diameter	7.4 m
--------------------	-------

Towing Bracket	Standard
----------------	----------

ROPS

For the UK and other markets where it is a legal requirement a fully approved folding ROPS frame is fitted as standard.

Optional Extras

Folding ROPS frame. Beacon. Full road lighting equipment. UK road equipment. Anti-theft device.

Thwaites

Thwaites Ltd. Leamington Spa, Warwickshire CV32 7NQ, England
Tel +44 (0)1926 422471 Fax +44 (0)1926 337155
www.thwaitesdumpers.co.uk

Distributor



We reserve the right to change all specifications without prior notice. Printed in England 09/2007.